

Eolis® modular shelving

Depth 400

- Welded steel ladder structure - epoxy painted (8 colours to choose from).
- U-shaped uprights braced by rectangular and square section tubes.
- Assembly of ladders and spacers by screws and nuts.
- Wall or back-to-back fasteners available as standard on fixed shelving to ensure the stability of the unit and allow the addition of telescopic parts (shelves, drawers).
- 1000 x 400 and 1200 x 400 racks fitted with rear stiffeners as standard.
- Fixed: adjustable pads to adapt to uneven floors.
- Mobile: 4 Ø 125 mm wheels in composite material - Wheels with brake optional

→ Mobile base - Width 1000 mm



1002.70

→ Fixed base + extension - Width 1000 mm

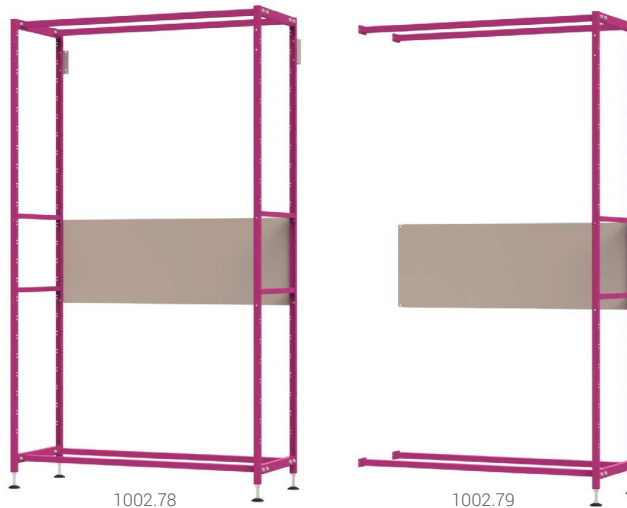

1002.78

1002.79

→ Double mobile bases

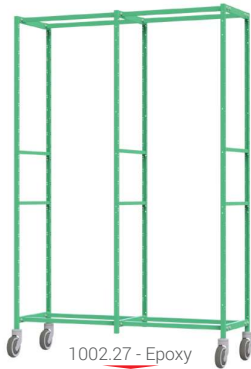

1002.27 - Epoxy



1002.37 - Stainless steel

→ FIXED AND MOBILE SHELVING - DEPTH 400

| WIDTH | LEVELS | FIXED SHELVING | | MOBILE SHELVING | |
|---------------------------------|-------------------------------------|----------------|-----------|-----------------|-----------|
| | | BASE | EXTENSION | BASE | EXTENSION |
| 600 mm | | 1002.31 | 1002.32 | 1002.26 | 1002.68 |
| 600 mm - Stainless steel | | 1002.41 | 1002.42 | 1002.36 | - |
| 1000 mm | 22 modules (straight runners) | 1002.78 | 1002.79 | 1002.70 | 1002.71 |
| 1200 mm | 20 modules (from 1 inclined runner) | 1002.82 | 1002.83 | 1002.74 | 1002.75 |
| Double 600 mm | | - | - | 1002.27 | - |
| Double 600 mm - Stainless steel | | - | - | 1002.37 | - |

Eolis[®] modular shelving

Depth 400

→ Examples of fixed shelving Base + extensions



Base 600 x 400 + extensions 600 x 400

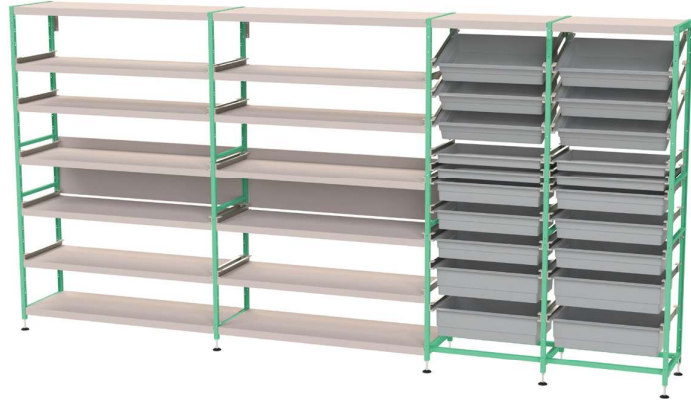

Base 1200 x 400 + extension 1200 x 400 + extensions 600 x 400

→ Examples of mobile shelving Base + extension



Base 1000 x 400

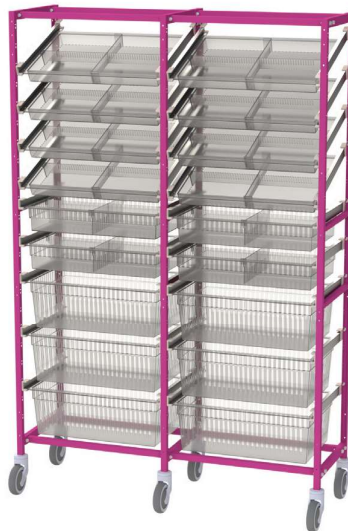

Base 600 x 400 + extension 600 x 400



Create your own fixed and mobile shelving - Depth 400 on the next page.



Need advice?
Contact your sales representative for a personalised study.
+33 285 290 506



See the **shelves and drawers** accessories available for modular shelving.

On the next page



We recommend that you assemble the mobile shelves (base + extension) up to a maximum width of 1200 mm. Beyond that, we recommend fixed shelving.

Characteristics



MAXIMUM LOADS

Racks (Bases/Extensions): **200 kg**
Fixed shelves: **80 kg**
Telescopic drawers or shelves: **50 kg**

AVAILABLE COLOURS



Create your Eolis® shelving

BASES + EXTENSIONS FOR FIXED AND MOBILE SHELVING - DEPTH 400

→ FIXED AND MOBILE BASES



FIXED SHELVES - STRAIGHT OR INCLINED

MAXIMUM LOADS Fixed shelves: 80 kg

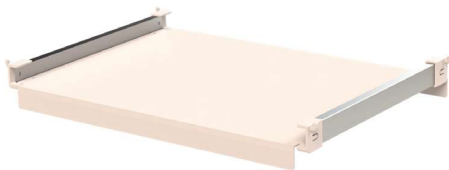

→ Fixed straight shelves with pair of runners

Fixed straight shelves with raised or dropped edges (reversible)

| DIM. L X W | REF. |
|---------------|---------|
| 600 x 400 mm | 1200.30 |
| 1000 x 400 mm | 1200.32 |
| 1200 x 400 mm | 1200.34 |

→ Fixed inclined shelves with pair of runners

Fixed inclined shelves with raised edges.

| DIM. L X W | REF. |
|---------------|---------|
| 600 x 400 mm | 1200.42 |
| 1000 x 400 mm | 1200.44 |
| 1200 x 400 mm | 1200.46 |

CONTAINERS WITH LIPS



→ Openwork containers with lip 600 x 400*

| MODEL | MATERIAL | REF. |
|------------------------------|----------------|---------|
| 1 module (full container) | Transparent PC | 1103.01 |
| | ABS grey | 1102.30 |
| 2 modules | Transparent PC | 1103.02 |
| | ABS grey | 1102.31 |
| 3 modules | Transparent PC | 1103.03 |
| | ABS grey | 1102.32 |

→ Full containers with lips - 600 x 400*

| MODEL | MATERIAL | REF. |
|-----------|----------|---------|
| 1 module | ABS grey | 1102.30 |
| 2 modules | ABS grey | 1103.80 |
| 3 modules | ABS grey | 1103.81 |

Remember to include 2 stops - Ref. 1102.39.

* For your modular shelving, include a pair of horizontal runners - Depth 400.

Remember to include 2 stops - Ref. 1102.39.

Depth 400

AVAILABLE COLOURS

Coral
 Safran
 Green
 Plum
 Grey
 Red
 Blue
 Lilac

Choice of fixed and mobile EXTENSIONS

Double Base 600 x 400



Mobile
1002.27

Extension 600 x 400



Fixed
1002.32

Extension 1000 x 400

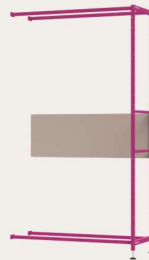

Fixed
1002.79

Extension 1200 x 400

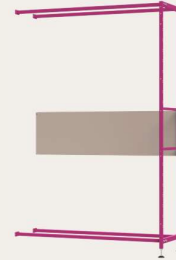

Fixed
1002.83

SEPARATORS



Separators for fixed shelves with edges

Depth 400 mm
Ref. 1200.48

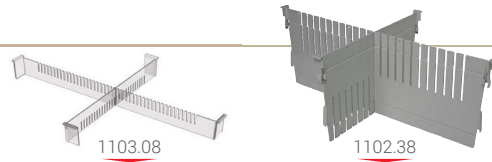

1103.08

1102.38

Separators for containers with lips 600 x 400

| MODEL | DIRECTION | TRANSPARENT PC | ABS GREY |
|-----------|-----------|----------------|----------|
| 1 module | P. 400 mm | 1103.07 | 1102.34 |
| | L. 600 mm | 1103.08 | 1102.33 |
| 2 modules | P. 400 mm | 1103.09 | 1102.36 |
| | L. 600 mm | 1103.10 | 1102.35 |
| 3 modules | P. 400 mm | 1103.11 | 1102.38 |
| | L. 600 mm | 1103.12 | 1102.37 |

CEILINGS/FLOORS



Ceilings/floors

Upper or lower shelves.

| DIM. L X W | REF. |
|---------------|---------|
| 600 x 400 mm | 1200.36 |
| 1000 x 400 mm | 1200.38 |
| 1200 x 400 mm | 1200.40 |

LABEL HOLDERS AND SUPPORTS

| | MODEL | REF. |
|--|----------------|---------|
| Transparent clip-on label holder | Vertical | 1102.69 |
| | Horizontal | 1106.06 |
| | Length 60 mm | 1102.70 |
| Transparent label holder for 600x400 containers | Length 100 mm | 1102.71 |
| | Length 330 mm | 1102.72 |
| | Length 530 mm | 1102.73 |
| Adhesive label holder | Length 60 mm | 1101.45 |
| | Length 350 mm | 1101.46 |
| | Length 1200 mm | 1200.69 |
| White label support for label holder | | 1102.74 |
| Protection for transparent horizontal label holder | | 1106.07 |

RUNNERS

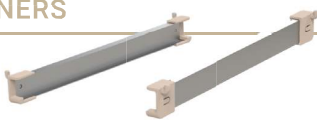

Pair of runners - Depth 400

| | |
|----------|---------|
| Straight | 1200.26 |
| Inclined | 1200.28 |

BRAKE WHEELS

Brake wheels Ø 125 mm



Replacement of 2 Ø 125 mm wheels with 2 Ø 125 mm brake wheels.
Ref. 1300.42

FIXINGS



Pair of fixings for mobile shelving

| MODEL | REF. |
|----------------------|---------|
| Wall fixings | 1200.24 |
| Back to back fixings | 1200.25 |

Eolis® modular shelving

Depth 600

- Welded steel ladder structure - epoxy painted (8 colours to choose from).
- U-shaped uprights braced by rectangular and square section tubes.
- Assembly of ladders and spacers by screws and nuts.
- Wall or back-to-back fasteners available as standard on fixed shelving to ensure the stability of the unit and allow the addition of telescopic parts (shelves, drawers).
- 1000 x 600 and 1200 x 600 racks fitted with rear stiffeners as standard.
- Fixed: adjustable pads to adapt to uneven floors.
- Mobile: 4 or 6 Ø 125 mm wheels in composite material - Wheels with brake optional.

→ Mobile base - Width 1000 mm

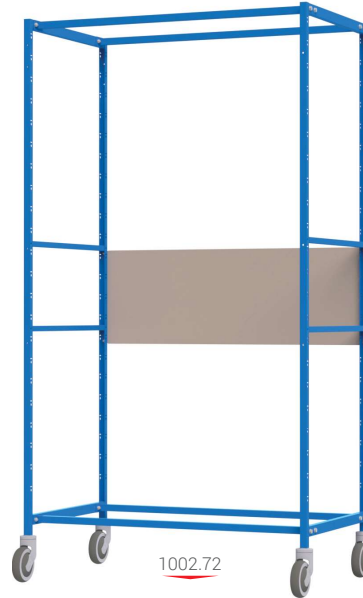

→ Fixed base + extension - Width 1000 mm

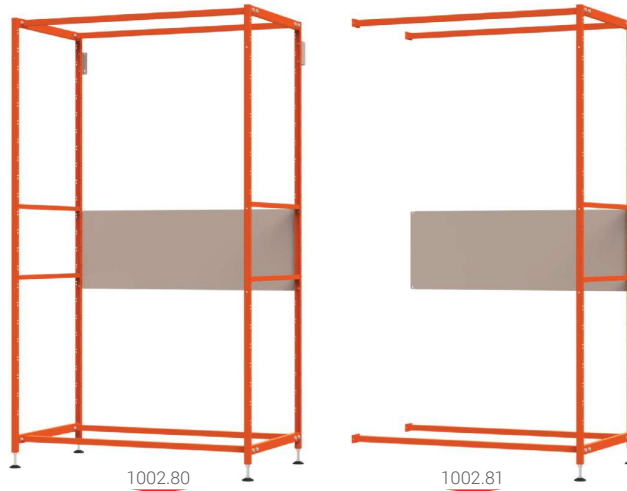

→ Triple mobile bases

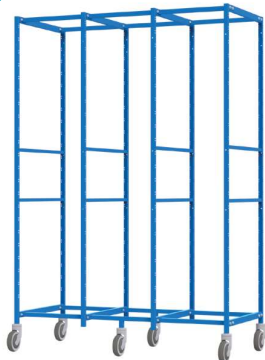

→ FIXED AND MOBILE SHELVING - DEPTH 600

| WIDTH | LEVELS | FIXED SHELVING | | MOBILE SHELVING | |
|---------------------------------|-------------------------------------|----------------|-----------|-----------------|-----------|
| | | BASE | EXTENSION | BASE | EXTENSION |
| 400 mm | | 1002.33 | 1002.34 | 1002.28 | 1002.69 |
| 400 mm - Stainless steel | | 1002.43 | 1002.44 | 1002.38 | - |
| 1000 mm | | 1002.80 | 1002.81 | 1002.72 | 1002.73 |
| 1200 mm | 22 modules (straight runners) | 1002.84 | 1002.85 | 1002.76 | 1002.77 |
| Double 400 mm | 20 modules (from 1 inclined runner) | - | - | 1002.29 | - |
| Double 400 mm - Stainless steel | | - | - | 1002.39 | - |
| Triple 400 mm | | - | - | 1002.30 | - |
| Triple 400 mm - Stainless steel | | - | - | 1002.40 | - |

Eolis[®] modular shelving

Depth 600

→ Examples of fixed shelving Base + extensions



Triple base 400 x 600 + extension 1200 x 600



Base 1200 x 600 + extension 1000 x 600 + extension 400 x 600

→ Examples of mobile shelving Base + extension



Base 400 x 600



Base 400 x 600 + extension 1000 x 600



Create your own fixed and mobile shelving - Depth 600 on the next page.



Need advice?
Contact your sales representative for a personalised study.
+33 285 290 506



See the **shelves and drawers** accessories available for modular shelving.

On the next page



We recommend that you assemble the mobile shelves (base + extension) up to a maximum width of 1200 mm. Beyond that, we recommend fixed shelving.

Characteristics



MAXIMUM LOADS

Racks (Bases/Extensions): **200 kg**
Fixed shelves: **80 kg**
Telescopic drawers or shelves: **50 kg**

AVAILABLE COLOURS



Create your shelving

BASES + EXTENSIONS FOR FIXED AND MOBILE SHELVING - DEPTH 600

→ FIXED AND MOBILE BASES

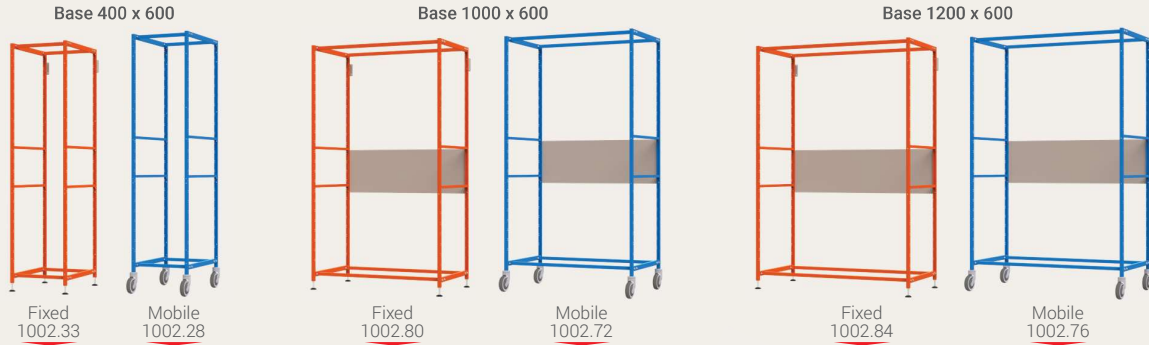

FIXED SHELVES - STRAIGHT OR INCLINED

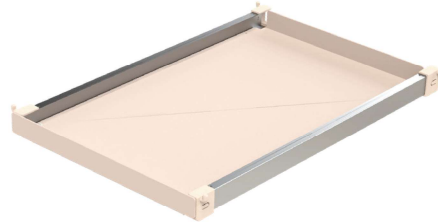
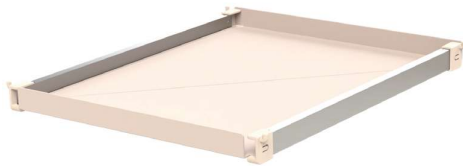
MAXIMUM LOADS Fixed shelves: 80 kg

→ Fixed straight shelves with pair of runners

Fixed straight shelves with raised or dropped edges (reversible)

| DIM. L X W | REF. |
|---------------|---------|
| 400 x 600 mm | 1200.31 |
| 1000 x 600 mm | 1200.33 |
| 1200 x 600 mm | 1200.35 |

→ Fixed inclined shelves with pair of runners

Fixed inclined shelves with raised edges.

| DIM. L X W | REF. |
|---------------|---------|
| 400 x 600 mm | 1200.43 |
| 1000 x 600 mm | 1200.45 |
| 1200 x 600 mm | 1200.47 |

CONTAINERS WITH LIPS



→ Openwork containers with lip 600 x 400*

| MODEL | MATERIAL | REF. |
|------------------------------|----------------|---------|
| 1 module (full container) | Transparent PC | 1103.01 |
| | ABS grey | 1102.30 |
| 2 modules | Transparent PC | 1103.02 |
| | ABS grey | 1102.31 |
| 3 modules | Transparent PC | 1103.03 |
| | ABS grey | 1102.32 |

Remember to include 2 stops - Ref. 1102.39.

→ Full containers with lips - 600 x 400*



| MODEL | MATERIAL | REF. |
|-----------|----------|---------|
| 1 module | ABS grey | 1102.30 |
| 2 modules | ABS grey | 1103.80 |
| 3 modules | ABS grey | 1103.81 |

Remember to include 2 stops - Ref. 1102.39.

* For your modular shelving, include a pair of horizontal runners - Depth 600.

Depth 600

AVAILABLE COLOURS

 Coral
  Safran
  Green
  Plum
  Grey
  Red
  Blue
  Lilac

Choice of fixed and mobile EXTENSIONS

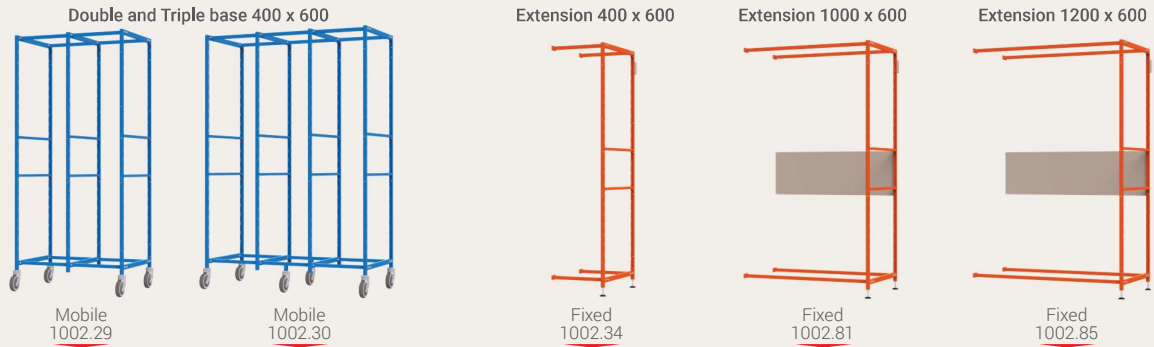

SEPARATORS



→ Separators for fixed shelves with edges

Depth 600 mm
Ref. 1200.49

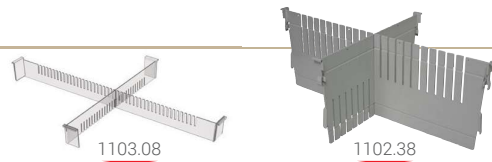

→ Separators for containers with lips 600 x 400

| MODEL | DIRECTION | TRANSPARENT PC | ABS GREY |
|-----------|-----------|----------------|----------|
| 1 module | P. 400 mm | 1103.07 | 1102.34 |
| | L. 600 mm | 1103.08 | 1102.33 |
| 2 modules | P. 400 mm | 1103.09 | 1102.36 |
| | L. 600 mm | 1103.10 | 1102.35 |
| 3 modules | P. 400 mm | 1103.11 | 1102.38 |
| | L. 600 mm | 1103.12 | 1102.37 |

CEILING/FLOORS



→ Ceilings/floors

Upper or lower shelves.

| DIM. L X W | REF. |
|---------------|---------|
| 400 x 600 mm | 1200.37 |
| 1000 x 600 mm | 1200.39 |
| 1200 x 600 mm | 1200.41 |

LABEL HOLDERS AND SUPPORTS

| | MODEL | REF. |
|--|----------------|---------|
| Transparent clip-on label holder | Vertical | 1102.69 |
| | Horizontal | 1106.06 |
| Transparent label holder for 600x400 containers | Length 60 mm | 1102.70 |
| | Length 100 mm | 1102.71 |
| | Length 330 mm | 1102.72 |
| | Length 530 mm | 1102.73 |
| Adhesive label holder | Length 60 mm | 1101.45 |
| | Length 350 mm | 1101.46 |
| White label support for label holder | Length 60 mm | 1101.45 |
| | Length 1200 mm | 1200.69 |
| White label support for label holder | | 1102.74 |
| Protection for transparent horizontal label holder | | 1106.07 |

RUNNERS



→ Pair of runners - Depth 600

| | |
|----------|---------|
| Straight | 1200.27 |
| Inclined | 1200.29 |

BRAKE WHEELS

→ Brake wheels Ø 125 mm



Replacement of 2 Ø 125 mm wheels with 2 Ø 125 mm brake wheels.
Ref. 1300.42

FIXINGS



→ Pair of fixings for mobile shelving

| MODEL | REF. |
|----------------------|---------|
| Wall fixings | 1200.24 |
| Back to back fixings | 1200.25 |