

Mobile Storage Shelving - Depth 400

EOLIS® 600x400

DEPTH 400 MOBILE SHELVING BASE SHELVING UNITS

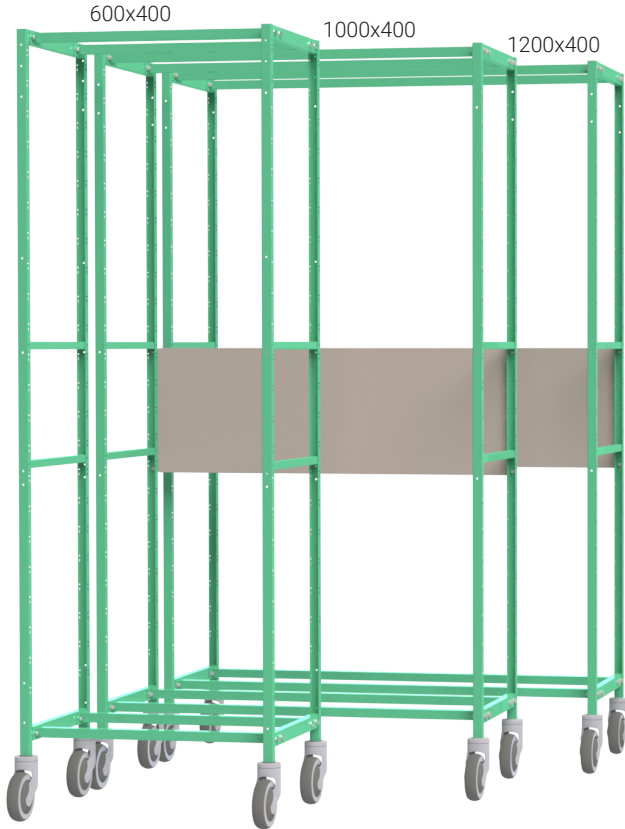

600x400 shelving unit base	Ref. 1002.26
Double 600x400 shelving unit	Ref. 1002.27
1000x400 shelving unit base*	Ref. 1002.70
1200x400 shelving unit base*	Ref. 1002.74

DEPTH 400 MOBILE SHELVING ADDITIONAL SHELVING SECTIONS

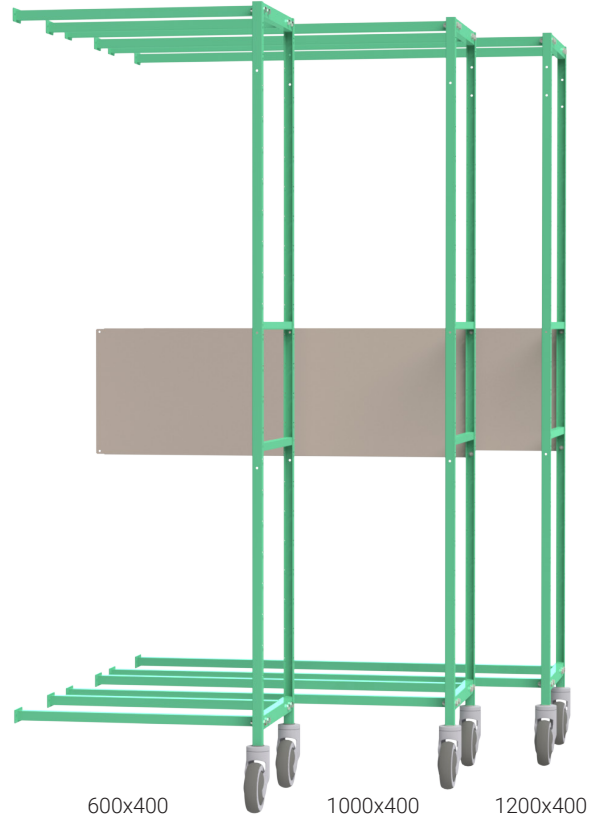

600x400 additional shelving section	Ref. 1002.68
1000x400 additional shelving section*	Ref. 1002.71
1200x400 additional shelving section*	Ref. 1002.75

> All this additional shelving sections above are not available for double 600x400 shelving unit.

FEATURES

ISO standard size 600x400 frames and equipments, fitting with all the Eolis® 600x400 product range (transfer & storage cabinets, workstations and drawers blocks, trolleys and carts).

- Welded lateral steel frames with epoxy coating (8 colours choice)
- «U» frame structure (ladder & strut) built with screws and nuts
- * 1000x400 and 1200x400 shelving furnished with back stiffener
- 4 polyamide wheels Ø125mm - Brakes as option
- Delivered knocked down

Maximum load capacity

Shelving (Base or Extension)	200kg
Fixed shelves	80kg

OVERALL DIMENSIONS (MM) :

Mobile shelving - Depth 400

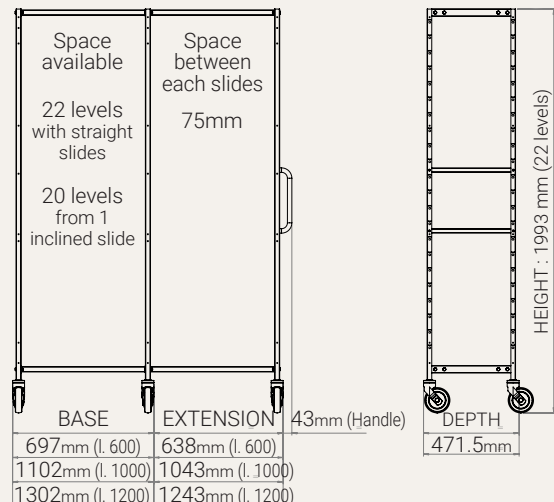

Create your Eolis® Storage Shelving

1 SELECT THE BASE UNITS + ADDITIONAL SECTIONS | DEPTH 400

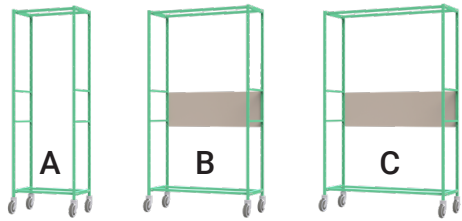

BASE

Shelving units BASE - Depth 400 :		
A. 600x400	Ref. 1002.26	
B. 1000x400*	Ref. 1002.70	
C. 1200x400*	Ref. 1002.74	

*furnished with back stiffener

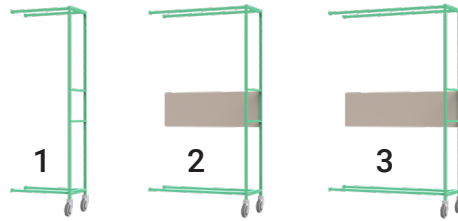

EXTENSIONS

ADDITIONAL shelving sections - Depth 400 :	
A. 600x400	Ref. 1002.68
B. 1000x400*	Ref. 1002.71
C. 1200x400*	Ref. 1002.75

> All the **ADDITIONAL** shelving sections below fit with all the **Shelving Units BASE**.

Double shelving unit - Depth 400 :
600x400 (2 x 22 levels) Ref. 1002.27

> Additional shelving sections are not available with double shelving unit 600x400.

2 FIXED SHELVES one pair of slides included

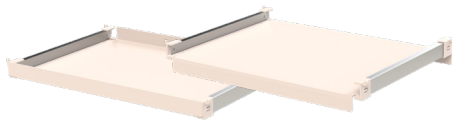

Fixed horizontal shelves with raised or turned down edges (reversible) - Depth 400:

600x400	Ref. 1200.30
1000x400	Ref. 1200.32
1200x400	Ref. 1200.34

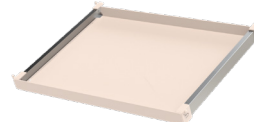
Fixed and inclined shelves with raised edges
Depth 400:

600x400	Ref. 1200.42
1000x400	Ref. 1200.44
1200x400	Ref. 1200.46

Extra Accessories for fixed shelves

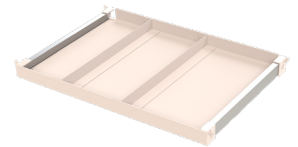
Divider for fixed shelves with raised edges - Depth 400
Ref. 1200.48

3 TELESCOPIC SHELVES/DRAWERS pair of telescopic slides included

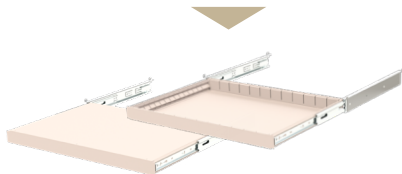

Telescopic shelves/drawers:

Depth 400	Shelves	Drawers
600x400 (W. 13 notches)	1200.50	1200.56
1000x400 (W. 21 notches)	1200.52	1200.58
1200x400 (W. 26 notches)	1200.54	1200.60

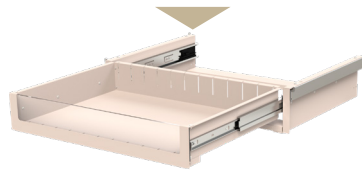

Telescopic drawers - Transparent front panel:

Depth 400	Horizontal	Inclined
600x400 (W. 12 notches)	1200.70	1200.75
1000x400 (W. 21 notches)	1200.71	1200.76
1200x400 (W. 25 notches)	1200.72	1200.77

Extra Accessories for telescopic drawers

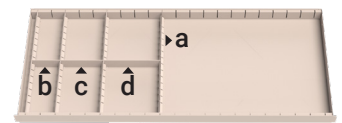

Dividers for telescopic drawers - Depth 400 :

a. Depth divider	Ref. 1200.80
b. Small divider*(2 notches - 90mm)	Ref. 1200.82
c. Medium divider*(3 notches - 137mm)	Ref. 1200.83
d. Large divider*(4 notches - 184mm)	Ref. 1200.84
* + a. Depth divider required	Ref. 1200.80

4 TOP/BOTTOM BRAKE WHEELS LABEL HOLDERS

Top or bottom shelves
Depth 400

600x400	Ref. 1200.36
1000x400	Ref. 1200.38
1200x400	Ref. 1200.40

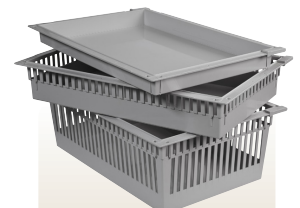
Additional cost for
2 brake wheels Ø125mm
Ref. 1300.42Adhesive label holder for drawers
or shelves
Ref. 1101.45EXTRA
ACCESSORIES
PAGES 50 - 51

Mobile Storage Shelving - Depth 600

EOLIS® 600x400

DEPTH 600 MOBILE SHELVING BASE SHELVING UNITS

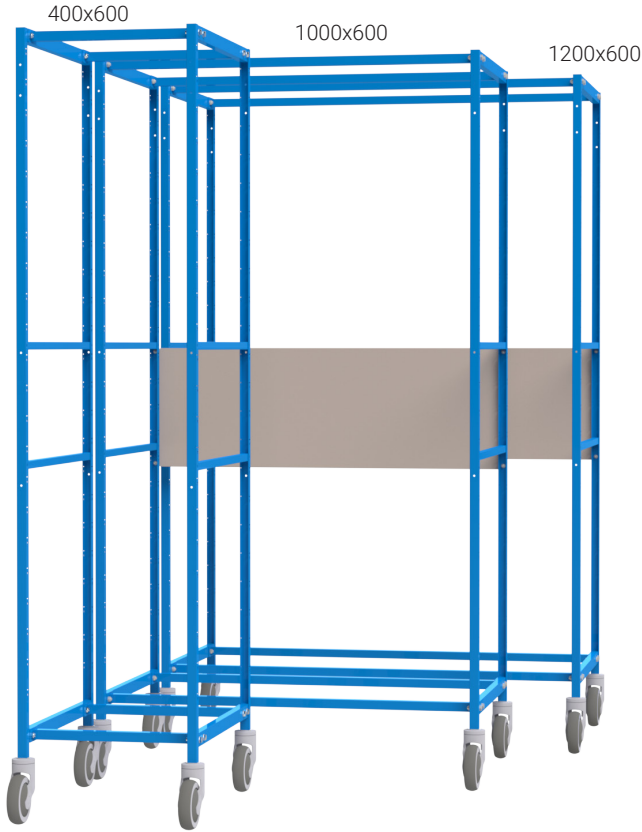

400x600 shelving unit base	Ref. 1002.28
Double 400x600 shelving unit	Ref. 1002.29
Triple 400x600 shelving unit	Ref. 1002.30
1000x600 shelving unit base*	Ref. 1002.72
1200x600 shelving unit base*	Ref. 1002.76

DEPTH 600 MOBILE SHELVING ADDITIONAL SHELVING SECTIONS

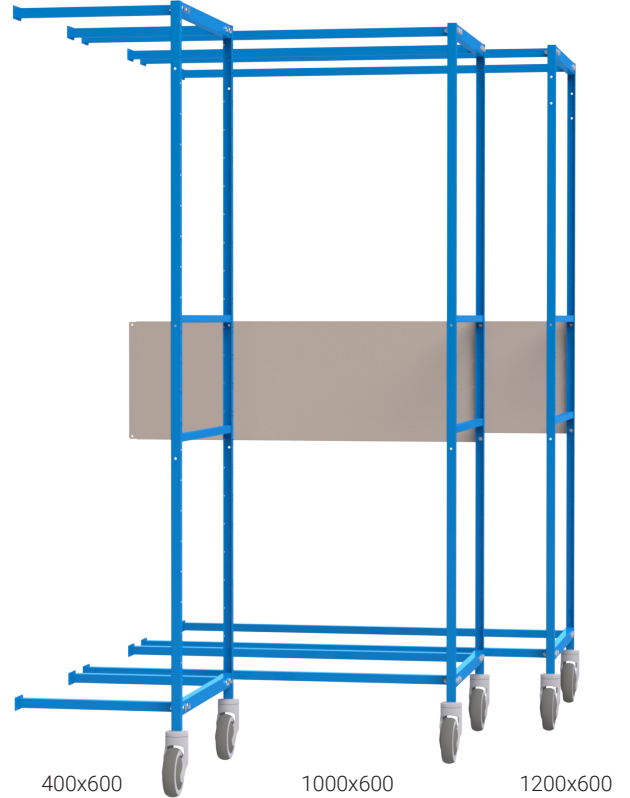

400x600 additional shelving section	Ref. 1002.69
1000x600 additional shelving section*	Ref. 1002.73
1200x600 additional shelving section*	Ref. 1002.77

> All this additional shelving sections above are not available for double and triple 400x600 shelving units.

FEATURES

ISO standard size 600x400 frames and equipments, fitting with all the Eolis® 600x400 product range (transfer & storage cabinets, workstations and drawers blocks, trolleys and carts).

- Welded lateral steel frames with epoxy coating (8 colours choice)
- «U» frame structure (ladder & strut) built with screws and nuts
- * 1000x400 and 1200x400 shelving furnished with back stiffener
- 4 polyamide wheels Ø125mm - Brakes as option
- Delivered knocked down

Maximum load capacity

Shelving (Base or Extension)	200kg
Fixed shelves	80kg

OVERALL DIMENSIONS : Mobile shelving - Depth 600

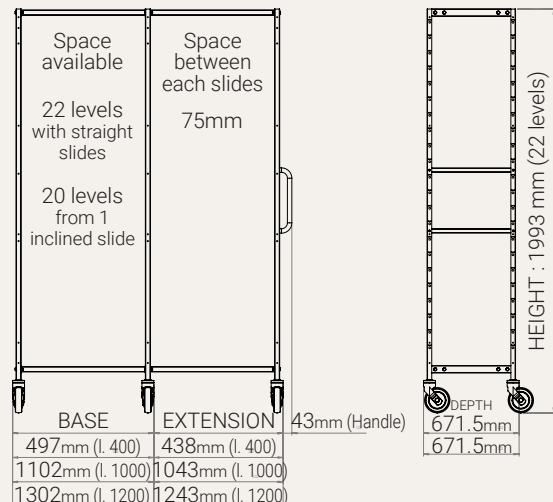

Create your Eolis® Storage Shelving

1 SELECT THE BASE UNITS + ADDITIONAL SECTIONS | DEPTH 600

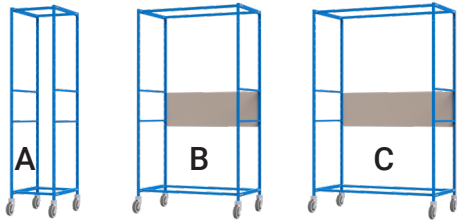

BASE

Shelving units BASE - Depth 600 :

A. 400x600	Ref. 1002.28
B. 1000x600*	Ref. 1002.72
C. 1200x600*	Ref. 1002.76

*furnished with back stiffener

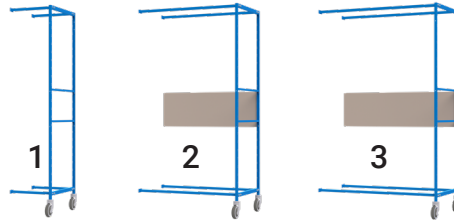

EXTENSIONS

ADDITIONAL shelving sections - Depth 600 :

A. 400x600	Ref. 1002.69
B. 1000x600*	Ref. 1002.73
C. 1200x600*	Ref. 1002.77

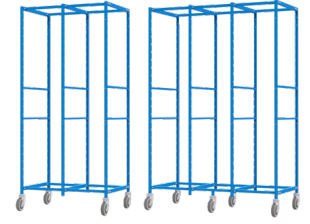
> All the **ADDITIONAL** shelving sections below fit with all the **Shelving Units BASE**.Double shelving unit 400x600
(2 x 22 levels)
Ref. **1002.29**Triple shelving unit 400x600
(3 x 22 levels)
Ref. **1002.30**

2 FIXED SHELVES one pair of slides included

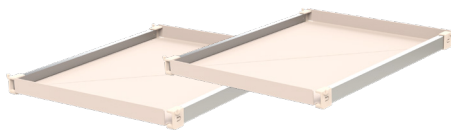

Fixed horizontal shelves with raised or turned down edges (reversible) - Depth 600

400x600	Ref. 1200.31
1000x600	Ref. 1200.33
1200x600	Ref. 1200.35

Fixed and inclined shelves with raised edges
Depth 600

400x600	Ref. 1200.43
1000x600	Ref. 1200.45
1200x600	Ref. 1200.47

Extra Accessories for fixed shelves

Divider for fixed shelves with raised edges - Depth 600
Ref. **1200.49**

3 TELESCOPIC SHELVES/DRAWERS pair of telescopic slides included

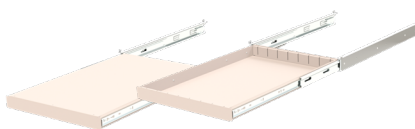

Telescopic shelves/drawers:

Depth 600	Shelves	Drawers
400x600 (W. 8 notches)	1200.51	1200.57
1000x600 (W. 21 notches)	1200.53	1200.59
1200x600 (W. 26 notches)	1200.55	1200.61

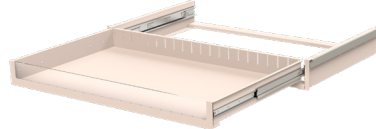

Telescopic drawers with transparent front panel:

Depth 600	Horizontal	Inclined
1000x600 (W. 21 notches)	1200.73	1200.76
1200x600 (W. 25 notches)	1200.74	1200.77

Extra Accessories for telescopic drawers

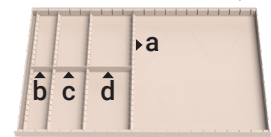

Dividers for telescopic drawers - Depth 600 :

a. Depth divider	Ref. 1200.81
b. Small divider* (2 notches - 90mm)	Ref. 1200.82
c. Medium divider* (3notches - 137mm)	Ref. 1200.83
d. Large divider* (4 notches - 184mm)	Ref. 1200.84

4 TOP/BOTTOM

Top or bottom shelves
Depth 600

400x600	Ref. 1200.37
1000x600	Ref. 1200.39
1200x600	Ref. 1200.41

BRAKE WHEELS

Additional cost for
2 brake wheels Ø125mm
Ref. **1300.42**

LABEL HOLDERS

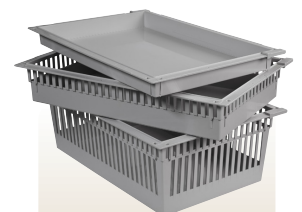
Adhesive label holder for drawers
or shelves
Ref. **1101.45**EXTRA
ACCESSORIES
PAGES 50 - 51

Example of equipped shelving

DOUBLE 600x400 SHELVING UNIT - MOBILE

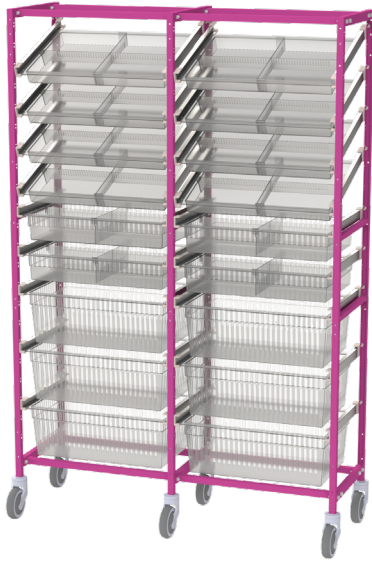

SHELVING UNIT BASE equipped with accessories
Double 600x400

Ref. **1002.26**

1000x400 SHELVING UNIT BASE - MOBILE



CONSTRUCTION:

1000x400 shelving unit base

Ref. **1002.70**

+ 1000x400 shelving section
equipped with accessories

Ref. **1002.71**

TRIPLE 400x600 SHELVING UNIT - FIXED

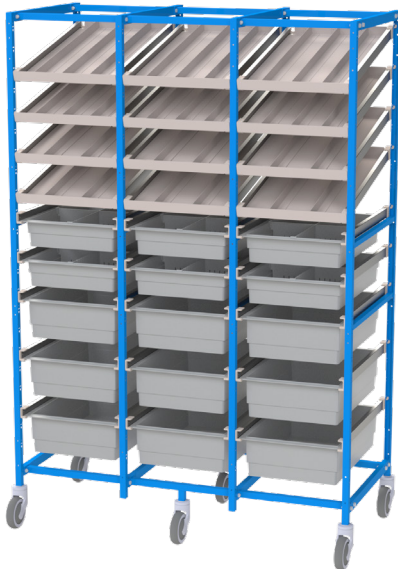

SHELVING UNIT BASE equipped with accessories
Triple 400x600

Ref. **1002.30**

400x600 SHELVING UNIT BASE - FIXED



CONSTRUCTION:

400x600 shelving unit base

Ref. **1002.28**

+ 1000x600 shelving section

Ref. **1002.73**

+ 400x600 shelving section
equipped with accessories

Ref. **1002.69**

CUSTOMIZE YOUR STORAGE SHELVINGS WITH ACCESSORIES PAGES 50 - 51

Sliding Shelving

EO'SLIDE® SOL

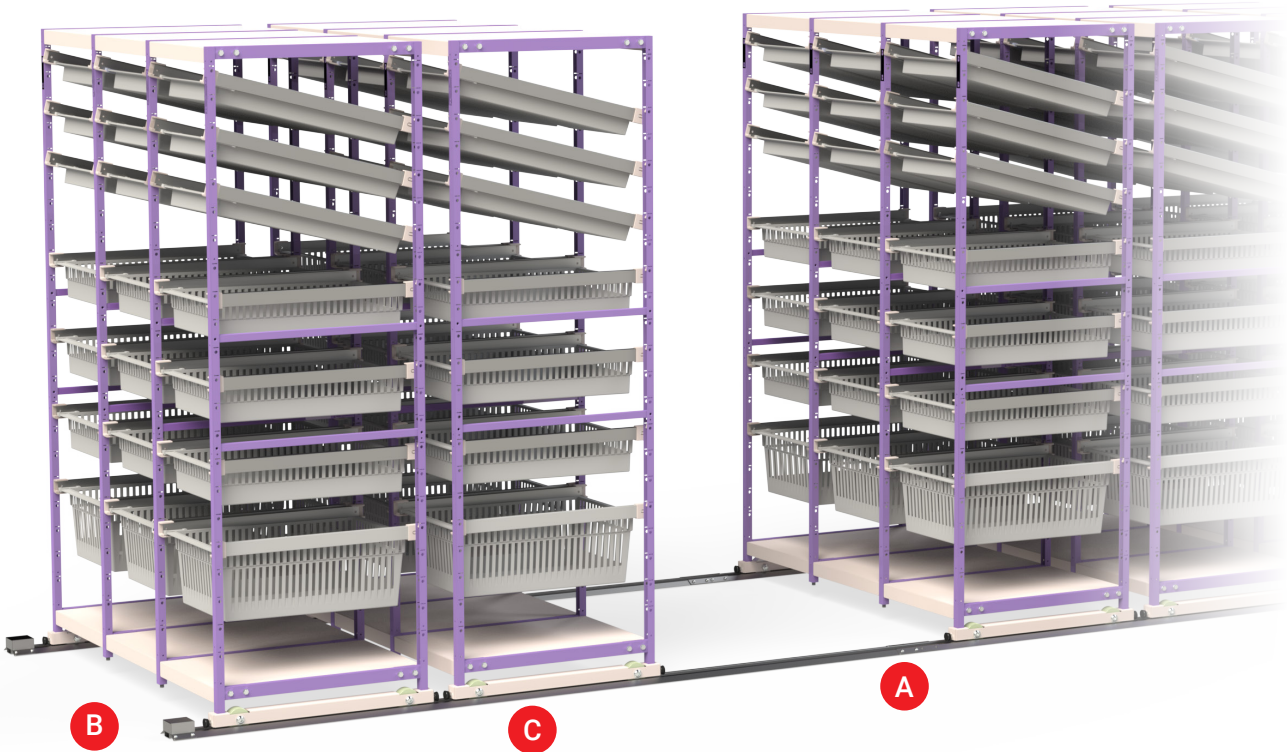

Top view :

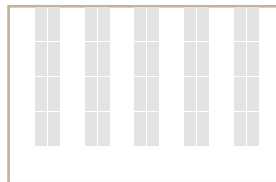

Layout with traditional shelving

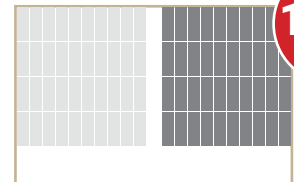

Layout with EO'SLIDE® sliding shelves

UNTIL
100%
MORE
STORAGE

Create your EO'SLIDE® SOL sliding shelves

A	Pair of EO'SLIDE® SOL rails (1 linear metre)	Ref. 1200.93
B	Kit of 4 end stops for EO'SLIDE® SOL	Ref. 1200.94
	EO'SLIDE® SOL guide kit for mobile shelving	
	Depth 400 - Single	Ref. 1200.95
C	Depth 600 - Single	Ref. 1200.96
	Depth 400 - Double	Ref. 1200.97
	Depth 600 - Double	Ref. 1200.98
	Identification plate for Eolis® modular shelving	
D	Depth 400	Ref. 1201.01
	Depth 600	Ref. 1201.02



1200.97

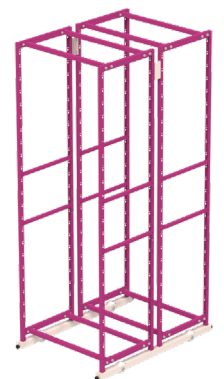

FEATURES

- Shelving system on EO'SLIDE® rails designed to optimize storage capacities
- Compatible with Eolis® fixed modular shelving bases - Depth 400 and 600 (single and double)
- Rails placed on the ground without making hole + mobile base (guide kit) for each mobile shelving
- Double mobile shelving can be constructed with the guide kits for back-to-back shelving

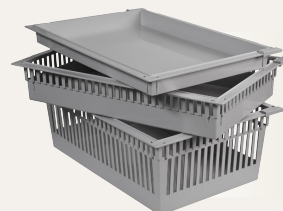

EXTRA
ACCESSORIES
PAGES 50 - 51

Extra accessories for storage shelving

NOMINATIVE PATIENT BINS for fixed shelves (horizontal & inclined) and tray - Ref. 1100.26

HEIGHT - 1 LEVEL

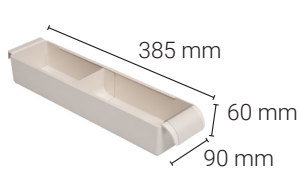

1 level 1/6 Ref. **1100.82**
Separation 1/6 Ref. **1100.89**

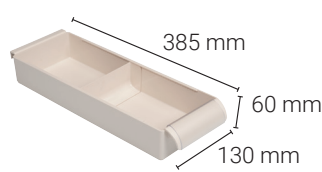

1 level 1/4 Ref. **1100.86**
Separation 1/4 Ref. **1100.91**

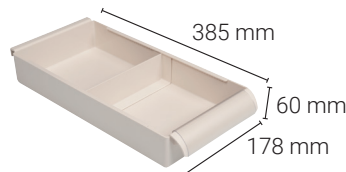

1 level 1/3 Ref. **1103.90**
Separation 1/3 Ref. **1103.93**

HEIGHT - 2 LEVELS

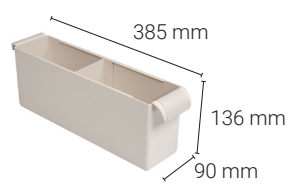

2 levels 1/6 Ref. **1100.84**
Separation 1/6 Ref. **1100.90**

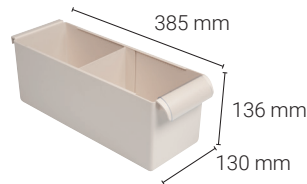

2 level 1/4 Ref. **1100.88**
Separation 1/4 Ref. **1100.92**

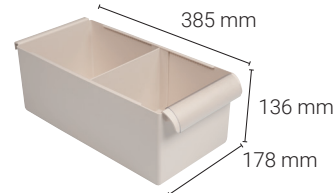

2 levels 1/3 Ref. **1103.92**
Separation 1/3 Ref. **1103.94**

Maximum quantity of nominative patient bins by shelves according to the dimensions

600x400 shelves

6 x 1/6 bins - 4 x 1/4 bins
3 x 1/3 bins

1000x400 shelves

10 x 1/6 bins - 7 x 1/4 bins
5 x 1/3 bins

1200x400 shelves

13 x 1/6 bins - 9 x 1/4 bins
5 x 1/3 bins

DRAWERS 600x400 (pair of slides not included)



Drawer 1 level Ref. **1600.30**
600 x 400 x 73 mm ext.
560 x 360 x 63 mm int.



Drawer 2 levels Ref. **1600.31**
600 x 400 x 149 mm ext.
560 x 360 x 139 mm int.



Drawer 3 levels Ref. **1600.32**
600 x 400 x 226 mm ext.
560 x 360 x 216 mm int.

TRAY 600x400



600x400 tray for nominative patient bins
Ref. **1100.26**

+ horizontal pair of slides required
Depth 400 Ref. **1200.26**

Only available for Depth 400 shelving

Only available for 600x400

SUBDIVISION BINS for drawers 600x400

HEIGHT - 1 LEVEL

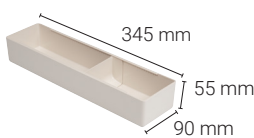

1 level 1/6 Ref. **1100.81**
Separation 1/6 Ref. **1100.89**

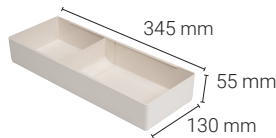

1 level 1/4 Ref. **1100.85**
Separation 1/4 Ref. **1100.91**

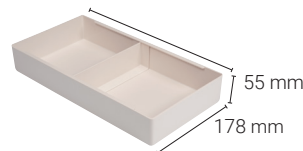

1 level 1/3 Ref. **1103.89**
Separation 1/3 Ref. **1103.93**

HEIGHT - 2 LEVELS

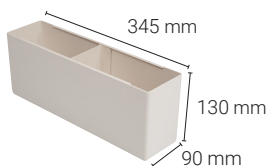

2 levels 1/6 Ref. **1100.83**
Separation 1/6 Ref. **1100.90**

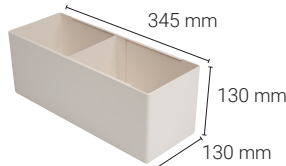

2 levels 1/4 Ref. **1100.87**
Separation 1/4 Ref. **1100.92**

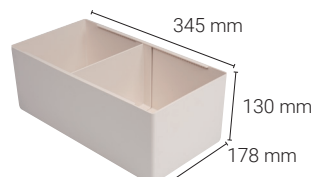

2 levels 1/3 Ref. **1103.91**
Separation 1/3 Ref. **1103.94**

RESIN SHELF



6mm thick antibacterial resin shelf
Ref. **1100.58**

+ horizontal pair of slides required
Depth 400 Ref. **1200.26**
Depth 600 Ref. **1200.27**

Available for 600x400 & 400x600

Extra accessories for storage shelving

1 MESHED BASKETS 600x400 (Clear PC or Grey ABS plastic)



Clear Polycarbonate 1 level standard basket Ref. **1103.01**

+ 2 end stops required
Ref. **1102.39**

+ pair of slides required
(see below)



Clear Polycarbonate 2 levels meshed basket Ref. **1103.02**

Grey ABS plastic 2 levels meshed basket Ref. **1102.31**

+ 2 end stops required
Ref. **1102.39**

+ pair of slides required
(see below)



Clear Polycarbonate 3 levels meshed basket Ref. **1103.03**

Grey ABS plastic 3 levels meshed basket Ref. **1102.32**

+ 2 end stops required
Ref. **1102.39**

+ pair of slides required
(see below)

STANDARD BASKETS 600x400 (Grey ABS plastic only)



Grey ABS plastic 1 level standard basket Ref. **1102.30**

+ 2 end stops required
Ref. **1102.39**

+ pair of slides required
(see below)



Grey ABS plastic 2 levels standard basket Ref. **1103.80**

+ 2 end stops required
Ref. **1102.39**

+ pair of slides required
(see below)



Grey ABS plastic 3 levels standard basket Ref. **1103.81**

+ 2 end stops required
Ref. **1102.39**

+ pair of slides required
(see below)



All baskets 600x400 (standard or meshed) fit fixed and mobile shelving Depth 400 & Depth 600

2 DIVIDERS for baskets 600x400 (Clear PC or Grey ABS plastic)

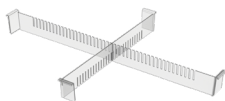

Clear Polycarbonate 600x50 divider Ref. **1103.08**

Clear Polycarbonate 400x50 divider Ref. **1103.07**

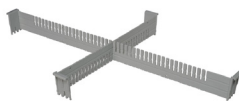

Grey ABS plastic 600x50 divider Ref. **1102.33**

Grey ABS plastic 400x50 divider Ref. **1102.34**

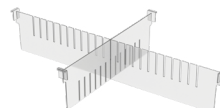

Clear Polycarbonate 600x100 divider Ref. **1103.10**

Clear Polycarbonate 400x100 divider Ref. **1103.09**

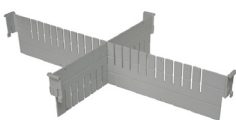

Grey ABS plastic 600x100 divider Ref. **1102.35**

Grey ABS plastic 400x100 divider Ref. **1102.36**

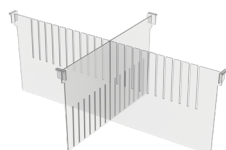

Clear Polycarbonate 600x200 divider Ref. **1103.12**

Clear Polycarbonate 600x200 divider Ref. **1103.11**



Grey ABS plastic 600x200 divider Ref. **1102.37**

Grey ABS plastic 600x200 divider Ref. **1102.38**

PAIR OF SLIDES



Pair of slides - Depth 400
Horizontal version Ref. **1200.26**
Inclined version Ref. **1200.28**

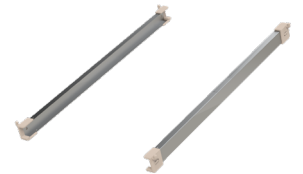

Pair of slides - Depth 600
Horizontal version Ref. **1200.27**
Inclined version Ref. **1200.29**

LABEL HOLDERS

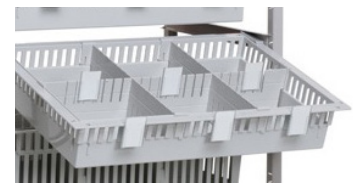

Vertical label holder
Clear Polycarbonate Ref. **1102.69**
PVC white plate Ref. **1102.74**



Horizontal label holder
Clear Polycarbonate Ref. **1106.06**
Horizontal label holder protection Ref. **1106.07**